

Tau330



Digital UV Inkjet Label Press

## Pre Installation Questionnaire

Distributor	Name	<input type="text"/>
	Contact/Sales Person	<input type="text"/>

Customer	Name	<input type="text"/>
	Street	<input type="text"/>
	City, (State,) Country	<input type="text"/>
	Contact Person	<input type="text"/>
	Phone	<input type="text"/>
	E-Mail / Web	<input type="text"/>

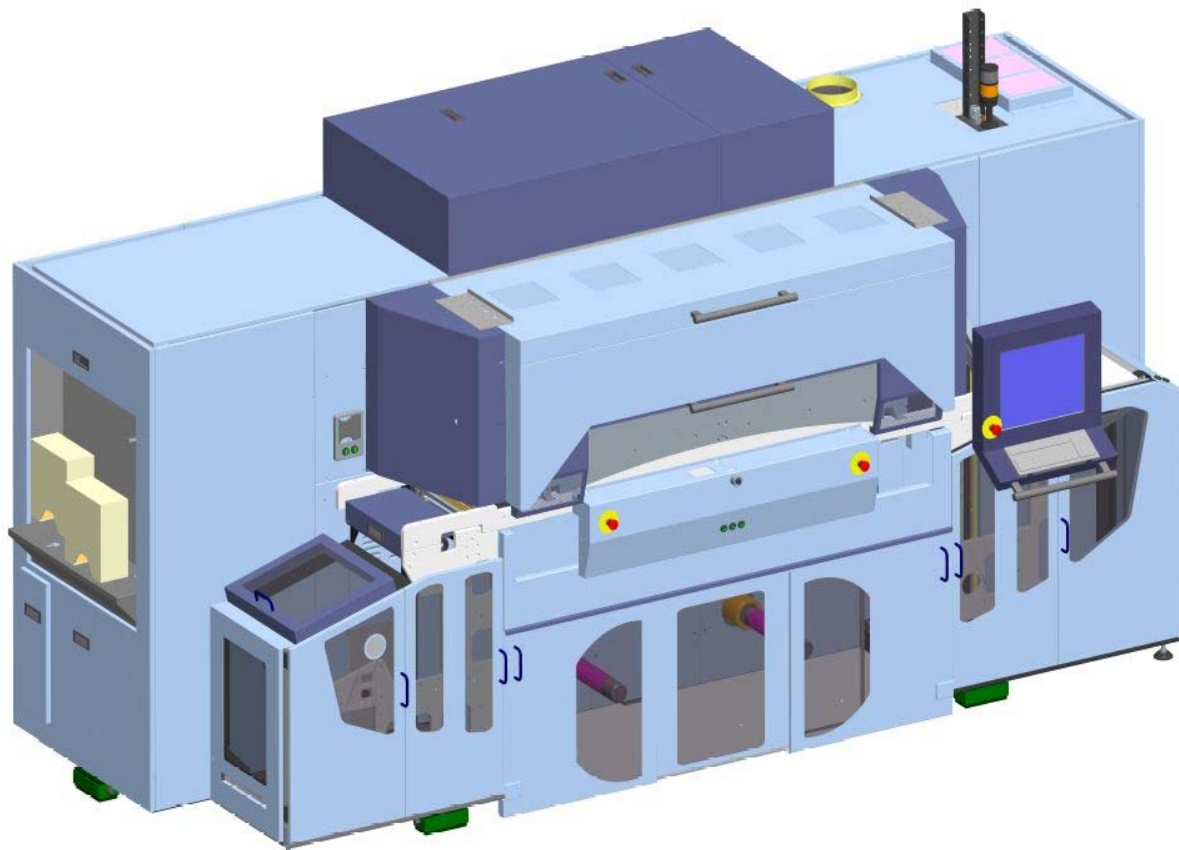

# 1 Shipping and Transport

## 1.1 Dimensions

Machine Size

Please see drawings below

Weight

Tau 330 cpl.	3500kg (7716lb)
Tau 330 cpl. + wooden pallet	3900kg (8598lb)
Tau 330 cpl. + wooden box	4200kg (9259lb)

## 1.2 Product version and machine accessories

Tau 330 CMYK	<input type="checkbox"/> OK
Tau 330 – 200	<input type="checkbox"/> OK
Chill Roller	<input type="checkbox"/> OK
Orange/Violet	<input type="checkbox"/> OK
White	<input type="checkbox"/> OK
Variable Data Printing Software	<input type="checkbox"/> OK
Laser Cutter (find Pre Installation questionnaire attached)	<input type="checkbox"/> OK

## 1.3 Ink Type

Tau Standard Ink	<input type="checkbox"/> OK
Tau Low Migration Ink	<input type="checkbox"/> OK

## 1.4 Requirements for Installation

Site Specification

Loading Ramp	<input type="checkbox"/> Yes	_____ (height)
Length of transport way		_____ (m)
Min. door opening	min. height 225cm (7'3")	<input type="checkbox"/> OK <input type="checkbox"/> NOT OK
Min. door opening	min. width 180cm (5'11") (for chill roller option min. 197 cm)	<input type="checkbox"/> OK <input type="checkbox"/> NOT OK
Door opening	(transport way)	_____ (width x height)

Machine room

Space required	Minimum 6m x 4,5m (height min 3m)	<input type="checkbox"/> OK <input type="checkbox"/> NOT OK
Room size		_____ (m x m)
Room height		_____ (m)
Max. floor loading capacity	Min. 50N/cm <sup>2</sup> (1300N/sq.in.)	<input type="checkbox"/> OK <input type="checkbox"/> NOT OK

### 1.5 Fork Lift Standards

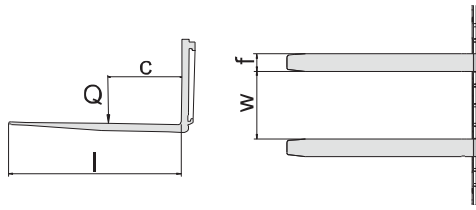

Fork lift available	<input type="checkbox"/> OK <input type="checkbox"/> NOT OK
Capacity	6000kg (13,228lb)
l (min. fork length) [cm (ft)]	200 (6'7")
w (min. fork dist.) [cm (ft)]	180 (5')
f (max. fork width) [cm (in)]	20 (7.8)



Special heavy-duty roller dollies need to be organized locally	<input type="checkbox"/> OK
--	-----------------------------

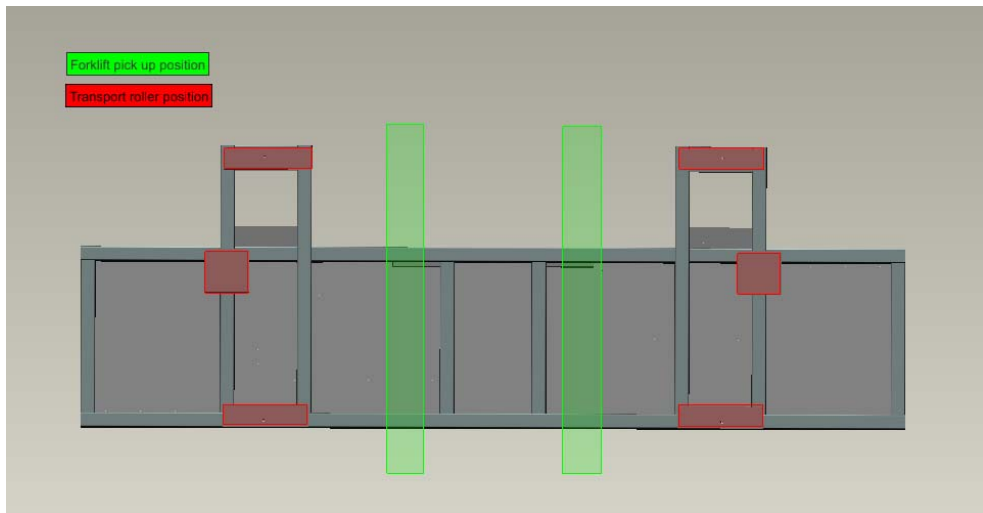

### 1.6 Storage

Lowest storage temperature prior to installation [°C (°F)]	4 (40)
Longest storage period prior to installation	Depending on shipping method, contact Service Department for info
Ware house available prior to install	<input type="checkbox"/> OK

## 2 Site Requirements

### 2.1 Power Supply

Ask your local authorized electrician for:

- Specifying the power supply cables and the safety switches or devices to match the national electrical safety regulations
- Carrying out the main power connection of the system (mandatory)

#### Main Unit (Printer)

Following main power supply is required

**3 Phase + N 230/400V (± 10 % / 39kVA 50/60Hz)**

Please *select* available power specification

EU-Norm

Phases	3 + N + PE 50Hz
Voltage [V]	400 (± 10%)
Max. power input [kVA]	39
Max. current per phase [A]	60
Min. conductor size	Cable 5x16 mm <sup>2</sup> 600VAC Type 8 AWG

US-Norm

Phases	3 + PE 60 Hz
Voltage [V]	208V (± 10%)
Max. power input [kVA]	40
Max. current per phase [A]	110
Min. conductor size	Cable 4x25 mm <sup>2</sup> 600VAC Type 4 AWG

Other Power Supply

Please Specify

---



---



---

Note: If the main power supply is of 3 phase without neutral, (i.e. US, Canada) the power cord between autotransformer and machine (5 x 8AWG) must be supplied by the customer.

OK

Important: The connection of the Tau 330 to the main power must be carried out by an authorized local electrician!  
All power cords must be IEC/UL approved!  
For USA and Canada: The installation must be done according to NEC requirements.

Connection type: Power Input Principle:  
The machine is build for fixed mains connection only. The power cord enters the Tau330 at the area described on chapter 4.3 (machine connections).

Disconnecting device: An IEC approved disconnecting device to disconnect all phases is supplied and already mounted on the Tau330.

Leakage current device: It is recommended to install a leakage current device. The leakage current device must be: **500mA** industrial type! → "All current sensitive". Check this with your local authorized electrician!

Note: If something in electrical installation will be modified after the system was installed, warranty will be void!

## 2.2 Air Supply

### 2.2.1 Compressed Air:

Pressure:	6 – 7 bar with 250 Liter/min. (dry air only) 150 – 130 psi with 65 Gallons/min.  Availability of air pressure must be assured at all times (24/7)!
Air specification classification:	Oil class 1 Particle class 1 Water class 4
Connection type:	Connection adapter will be delivered, only tube is required. The tube must have an inside diameter of 8mm (315mil.)

### 2.2.2 Ventilation:

Recommendation	The Tau 330 produces hot air (60-70°C) which should be dissipated by an appropriate exhaust system.
Location:	One exhaust tubes must be installed on top of the machine. It is necessary to install an external fan which extracts air from the machine.
Note:	The exhaust tube and the external fan are not supplied with the machine and must be organized by the customer. There is a floating contact in the machine which can be used to control the exhaust fan.
Performance of air:	Min 2000 m <sup>3</sup> /h (70,000cu.ft/h) at the machines output. Pipes, bows, etc. have to be considered
Connecting tube:	1x Ø 20cm / 7,87 inch

## 2.3 Operating Conditions

Maximum Altitude:	1000 m (3280 ft) above sea level
Temperature Range:	+18 to +28°C (+64 to +82°F)
Relative Humidity:	40-70% relative humidity of air (non-condensing)
Room:	"Dust-free", protect Tau330 from dust. (especially production area with grinding machines)

## 2.4 Network/Physical

Fast Ethernet for 1Gbit (1000Base TX) (Standard)	The Fast Ethernet (PCI 1Gbit), 4 lead twisted pair cable with RJ45 (Cat. 6) to connect the RIP workstation to the Mac, PC or servers is not included and must be supplied by the customer.
	The Durst technician will connect the Tau 330 and the RIP workstation with the existing network. Tau330, RIP Workstation and Prepress Station must be integrated to the existing network.

Network Protocol	reserved IP address: RIP _____ (i.e. 192.0.0.30)
	reserved IP address: Tau _____ (i.e. 192.0.0.32)
	reserved NIKKACamSystem _____ (i.e. 192.0.0.33) (optional)
	reserved subnet mask _____ (i.e. 255.255.255.0)

The here defined computer names of RIP and Workstation will be used in the factory for installation of the system. These names can not be changed during installation anymore!

default TAU computer name:	DURST-TAU330-B
Only if necessary please note here required RIP computer name:	_____ (i.e. TAU_STATION) <input type="checkbox"/> OK
default RIP computer name:	TAU-ESKO-SERVER
Only if necessary please note here required RIP computer name:	_____ (i.e. TAU_RIP) <input type="checkbox"/> OK

For the connection to other devices and loading the appropriate software a network specialist must be available during the installation.

**Note:** The internet connection must be permanent and always available for Durst Service.  
Constant Internet connection for REMOTE ACCESS (Teamviewer)  OK  
For more information please contact Durst Service Department (support@durst-online.com)

**Prepress Station:** Customer must make available a Prepress PC (Windows or MAC) to adapt/manage colors, prepare files, create options.  
Necessary Program: Adobe Illustrator minimum CS3.  
The necessary Plug-ins for Illustrator are supported by Durst Service during Installation.

### 3 Water Cooler (only for chill roller option)

#### 3.1 Power Supply

Ask your local authorized electrician for:

- Specifying the power supply cables and the safety switches or devices to match the national electrical safety regulations
- Carrying out the main power connection of the system (mandatory)

#### Main Unit (Printer)

Following main power supply is required

**3 Phase + N + PE 400V (± 10 % / 5,4kVA 50/60Hz)**

Please select available power specification

EU/US-Norm	<input type="checkbox"/>	Phases	3 + N + PE 50/60Hz	
		Voltage [V]	400 (± 10%)	
		Max. power input [kVA]	5,4	
		Max. current per phase [A]	6	
		Min. conductor size	EU 4x5 mm <sup>2</sup>	US 4x5mm <sup>2</sup>
			10 AWG	10 AWG

Other Power Supply

Please Specify

---



---



---

Note: If the main power supply is of 3 phase without neutral, (i.e. US, Canada) the power cord between autotransformer and machine (5 x 10AWG) must be supplied by the customer. The chiller must be connected to the autotransformer.

OK

**Important:** The connection of the Chiller to the main power must be carried out by an authorized local electrician!  
 All power cords must be IEC/UL approved!  
 For USA and Canada: The installation must be done according to NEC requirements.

**Disconnecting device:** An IEC approved disconnecting device to disconnect all phases is supplied and already mounted on the chiller.

Note: If something in electrical installation will be modified after the system was installed, warranty will be void!

The distance between Tau330 and water cooler has to be less than 30 m. The level difference from Tau330 to water cooler has to be less than 7 m.

## 4 Dimensions / Space Requirements

### 4.1 Tau330 Dimension and working space (red rectangle / top view):

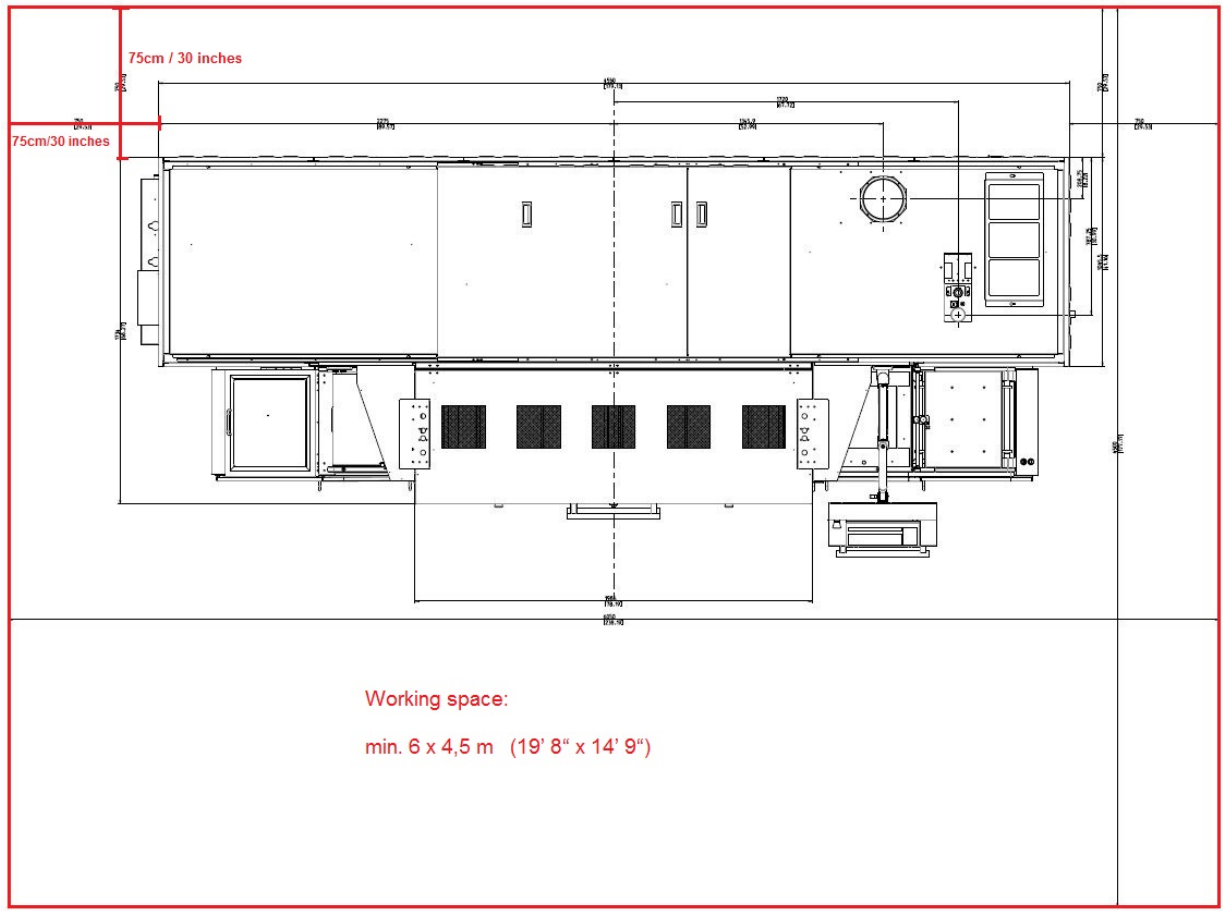

### 4.2 Front view:

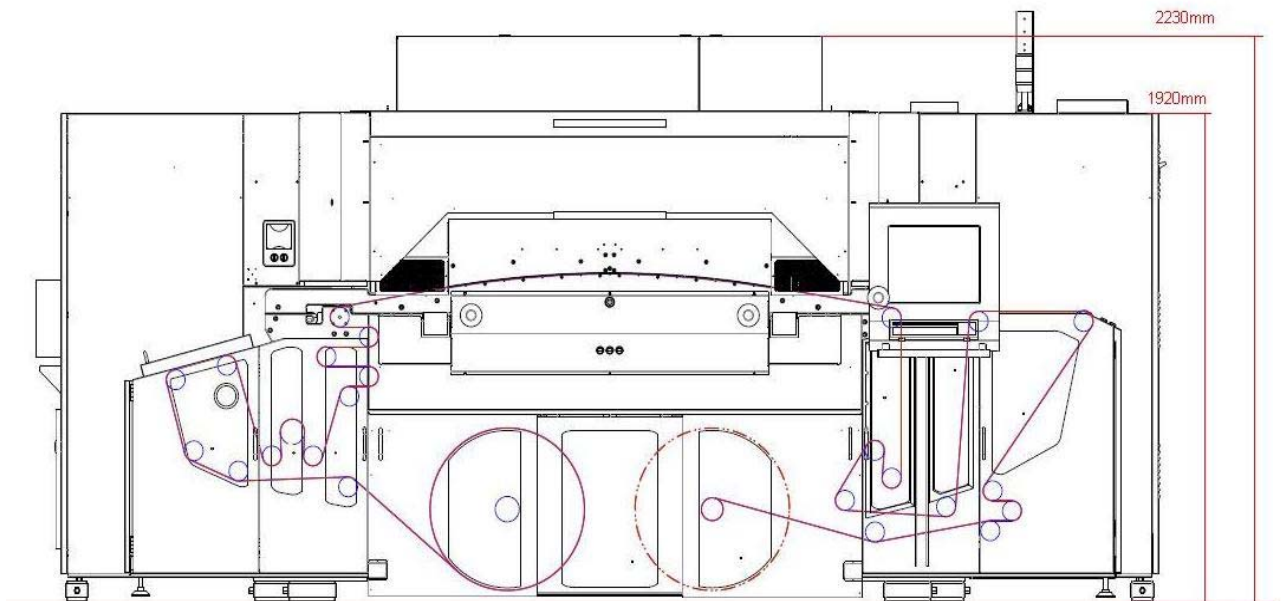



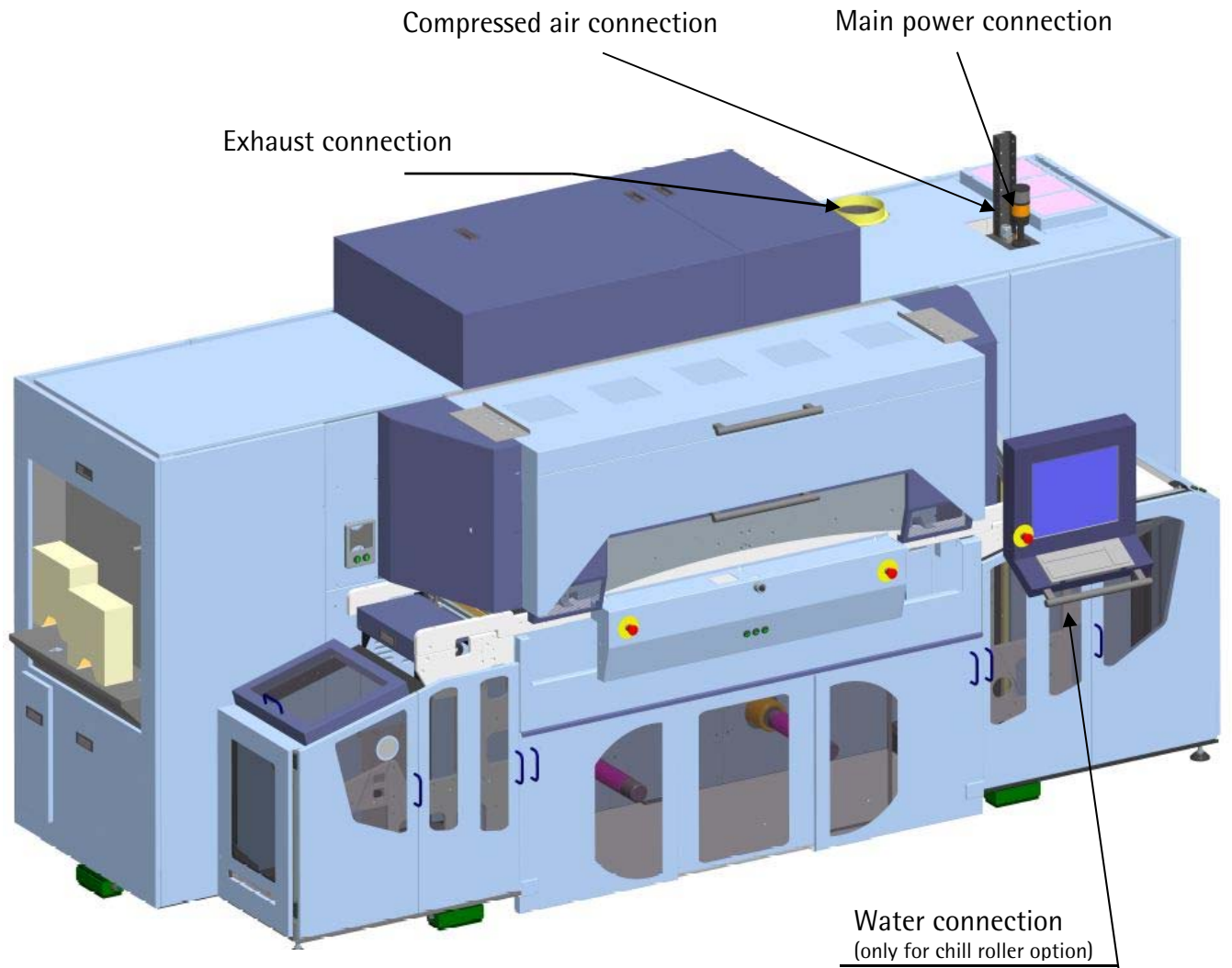

### 4.3 Machine connections:

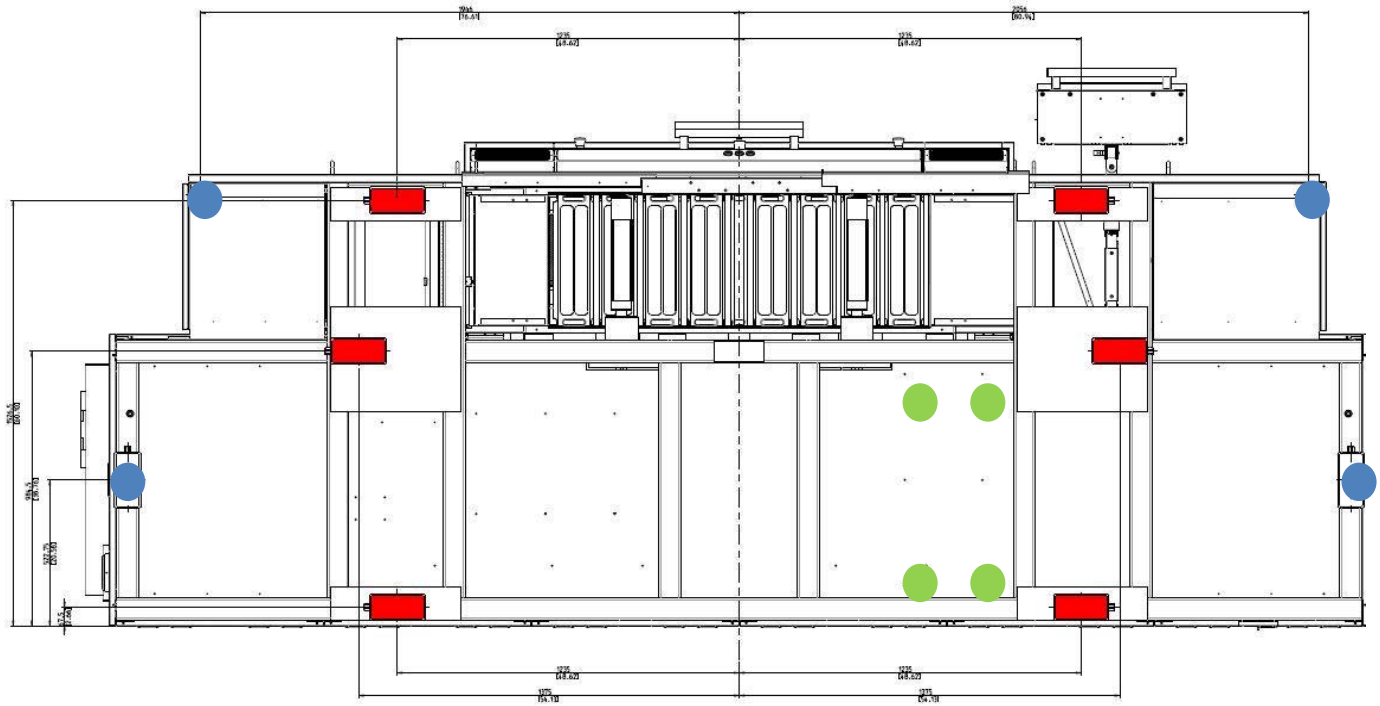

#### 4.4 System Leveling Points:



 leg supports

 leveling points

 leg supports UV exhaust fan

